

Assembly instructions – maintenance instructions

You can use these assembly instructions to assemble your PicnixX product.

After you have assembled the product, the fibres of the Cumaru hardwood may feel slightly rough. We advise sanding the Cumaru wood very lightly with the supplied sanding paper. Subsequently, the Cumaru wood will not require any maintenance.



If your product is equipped with Mounting Clips, these must be attached with the supplied mounting instructions.

Attach the parts with the stainless steel M10 hexagon bolts, stainless steel washers, nylon washers and M10 nuts. Apply a small amount of copper grease to the bolts.

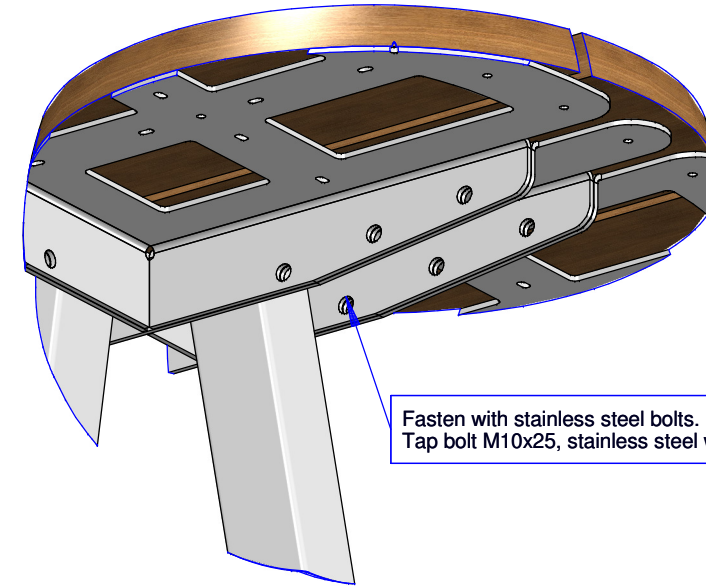
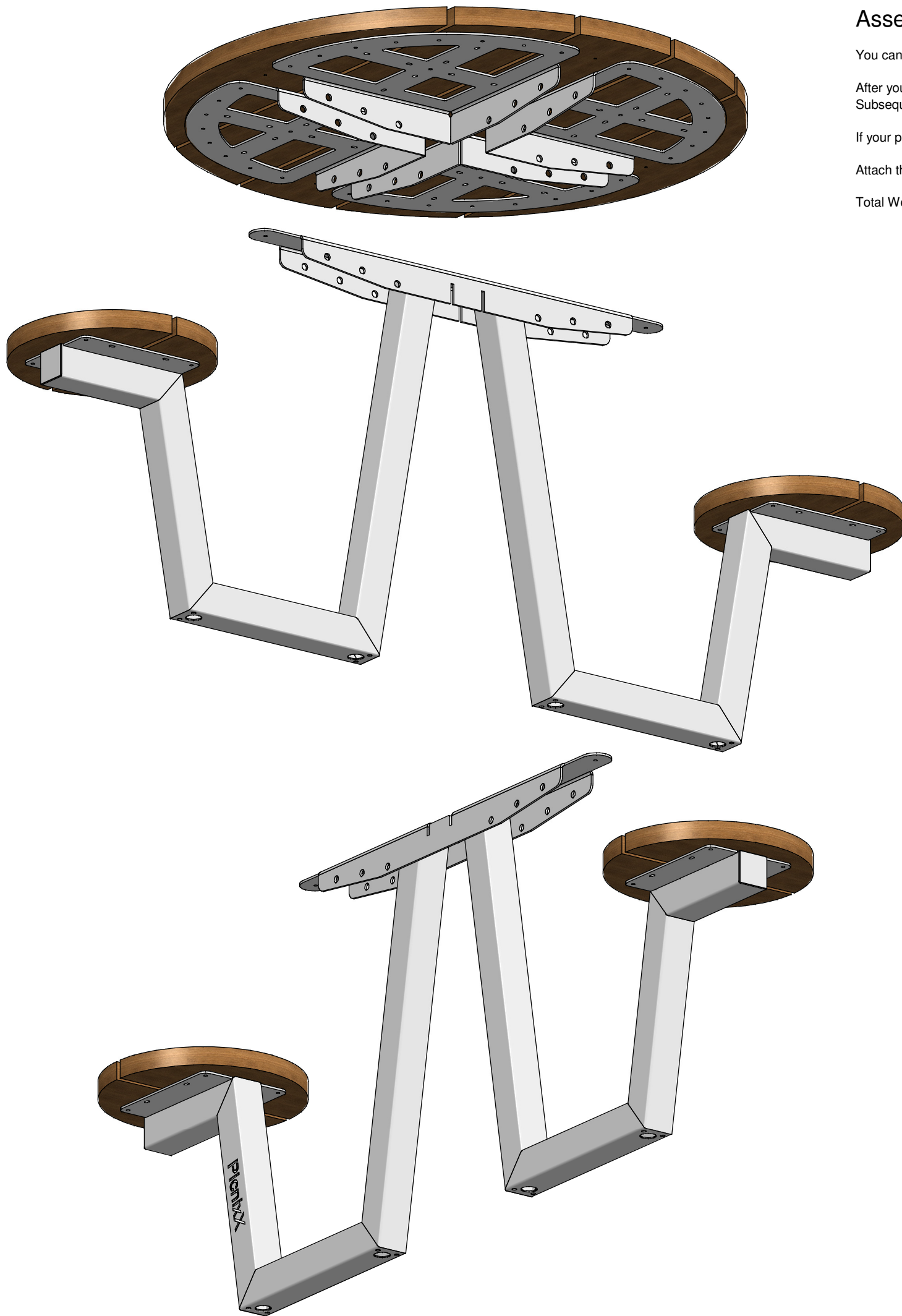
Total Weight: 85Kg



Fasten with stainless steel bolts.
Tap bolt M10x25, stainless steel washers, nylon washers and nut M10.

 PicnixX	Client:	Scale: 1:VAR.	Measure: mm	Material: Stainless steel
	Reference:	<h1>Miss Mini</h1>		
	Created:			
Realization class: 2	Checked:	<h2>Assembly instructions – maintenance instructions</h2>		
Manufacturing conform: NEN-EN1090-2:2008+A1:2011	Date: 12.03.2024			
Tolerance class conform NEN-ISO 2768-1: m Tolerance tables in EPCS	Projection (NEN 2351) 			
Conservation: Powder coated	All rights reserved: None of this subject or drawing may be further reproduced or stored in an automated database, or made public, in any form or by any means, either electronic, mechanical, photocopying, recording or otherwise, without prior notice written permission from PicnixX. Infringement of these rights leads to legal consequences for the violator.			
Colour: RAL 7024 (dark gray) / RAL 9016 (white)	Material types and qualities: plates and profiles S235JR according to NEN-EN 10025-2. Tube and box profiles: S275J0H according to NEN-EN 10210-1 (hot-rolled), according to NEN-EN 10219-1 (cold-rolled). Weld 0.5x thinnest adjacent web thickness but minimum a5, unless otherwise stated, conform NEN-EN-ISO 2553:2014. Bolt quality 8.8 unless otherwise stated.			
- - - -	- - - -	- - - -	- - - -	- - - -
Index	Revision	Date	Name	A3